

Prosilica GE

1660



- 34 fps @ 1.9 Megapixel
- OnSemi KAI-02050 sensor
- Galvanically isolated I/O
- Various mount options

Description

1.9 megapixel CCD camera with GigE Vision interface - More than 30 fps

Prosilica GE1660 is a high-resolution CCD camera with Gigabit Ethernet interface (GigE Vision®). GE1660 incorporates a high-quality 2/3" OnSemi KAI-02050 CCD sensor providing excellent monochrome and color image quality in 4:3 format. GE1660 runs 34 frames per second at 1600 x 1200 resolution and even faster with region of interest readout.

Options

- IR cut filter (monochrome cameras)
- Taped cover glass with or without microlenses
- Various lens mounts

Specifications

Prosilica GE	1660
Interface	IEEE 802.3 1000baseT
Resolution	1600 × 1200
Sensor	OnSemi KAI-02050
Sensor type	CCD Progressive
Cell size	5.5 μm
Lens mount	C-Mount
Max frame rate at full resolution	34 fps
ADC	12 bit
On-board FIFO	32 Mbyte
Output	
Bit depth	8/12 bit
Mono modes	Mono8, Mono12, Mono12Packed

Prosilica GE	1660
Color modes RGB	RGB8Packed, BGR8Packed, RGBA8Packed, BGRA8Packed, RGB12Packed
Raw modes	BayerGR8, BayerGR12, BayerGR12Packed
General purpose inputs/outputs (GPIOs)	
TTL I/Os	1 input, 3 outputs (with galvanic isolation)
RS-232	1
Operating conditions/dimensions	
Operating temperature	0°C ... +50°C
Power requirements (DC)	5V - 24V
Power consumption (@12 V)	5 W
Mass	178 g
Body dimensions (L × W × H in mm)	80 × 51 × 39 including connectors, w/o tripod and lens
Regulations	CE, FCC Class A, RoHS (2011/65/EU)

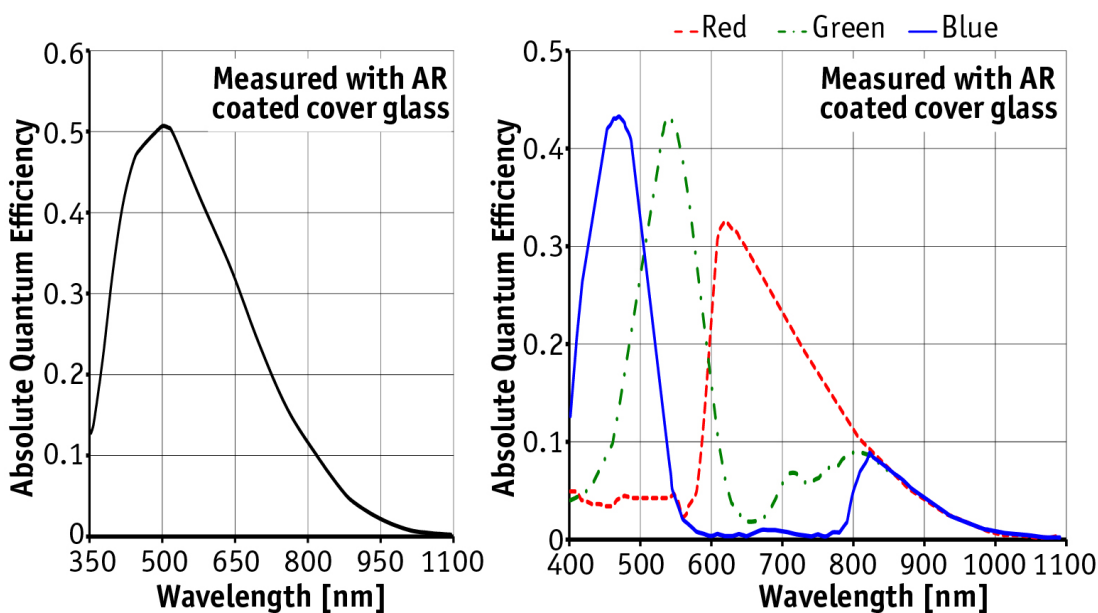

Features

Prosilica GE1660 features include:

- ROI, DSP subregion (selectable ROI for auto features)
- Binning
- Auto gain (manual gain control: 0 to 34 dB)
- Auto exposure (manual exposure controls: 10 μ s to 53.7 s)



- Auto white balance
- StreamBytesPerSecond (easy bandwidth control)
- Stream hold
- Sync out modes: Trigger ready, input, exposing, readout, imaging, strobe, GPO
- Global shutter (digital shutter)
- Recorder and Multiframe acquisition modes
- Event channel
- Chunk data
- Storable user sets

Technical drawing

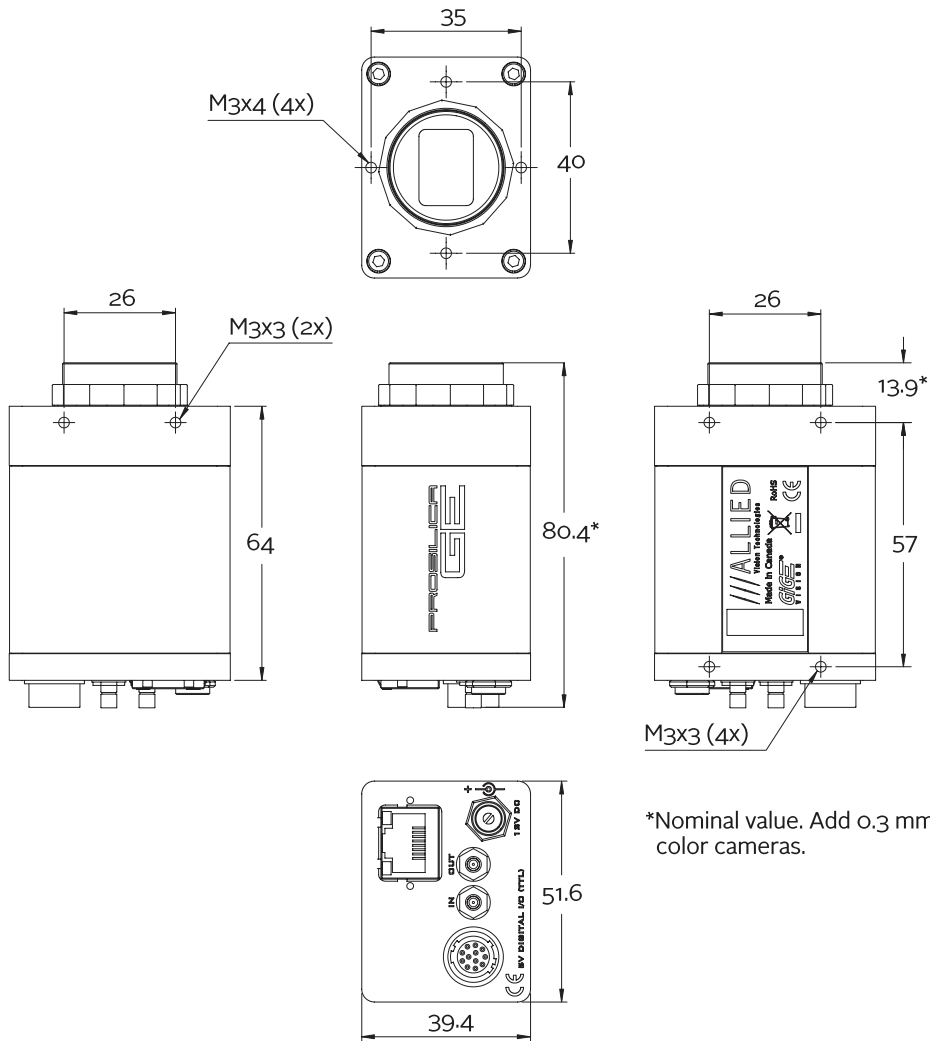

*Nominal value. Add 0.3 mm for color cameras.



Applications

Prosilica GE1660 is ideal for a wide range of applications including:

- Industrial inspection
- Machine vision
- LCD panel inspection
- Medical imaging
- Ophthalmology
- Aeronautical and aerospace
- Public security
- Surveillance
- Traffic imaging
- OEM applications