

Prosilica GC

750



- Compact
- High frame rate
- Rugged housing
- Video-type auto iris

Description

Low cost Gigabit Ethernet camera - 67 fps

Prosilica GC750 is an ultra-compact, economically priced, machine vision camera with Gigabit Ethernet interface (GigE Vision). GC750 runs 67 frames per second at 752x480 resolution over the GigE Vision-compliant Gigabit Ethernet interface.

Options

- IR cut filter

Specifications

Prosilica GC	750
Interface	IEEE 802.3 1000baseT
Resolution	752 × 480
Sensor	Micron/Aptina MT9V022
Sensor type	CMOS Progressive
Sensor size	Type 1/3
Cell size	6 μm
Lens mount	CS
Max frame rate at full resolution	67 fps
ADC	10 bit
On-board FIFO	16 Mbyte
Output	
Bit depth	8/10 bit
Mono modes	Mono8, Mono10

Prosilica GC	750
Color modes RGB	RGB8Packed, BGR8Packed, RGBA8Packed, BGRA8Packed
Raw modes	BayerBG8, BayerBG10
General purpose inputs/outputs (GPIOs)	
TTL I/Os	1 input, 1 output
Opto-isolated I/Os	1 input, 1 output
RS-232	1
Operating conditions/dimensions	
Operating temperature	0°C ... +50°C
Power requirements (DC)	5-25 VDC*
Power consumption (@12 V)	2.2 W
Mass	85 g
Body dimensions (L × W × H in mm)	45 × 46 × 33 including connectors, w/o tripod and lens
Regulations	CE, FCC Class A, RoHS (2011/65/EU)

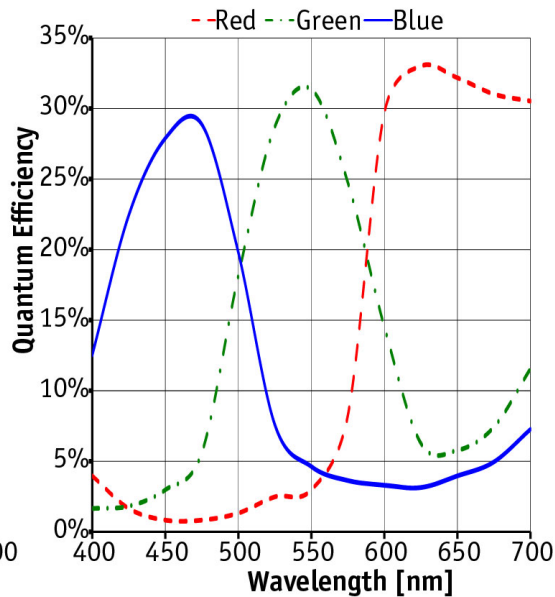
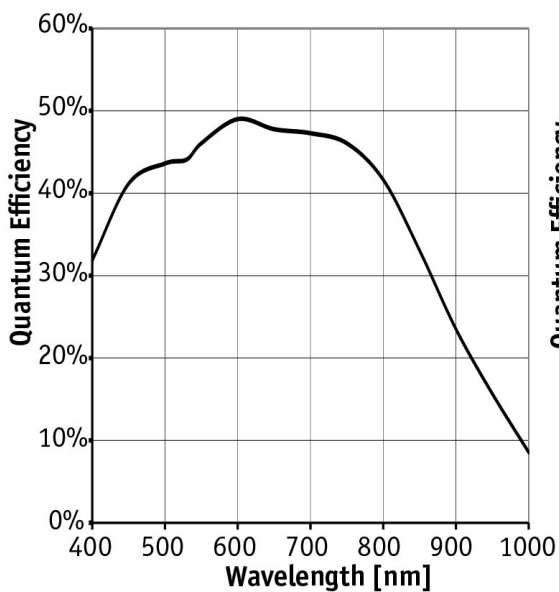

Features

Prosilica GC750 features include:

- Video-type auto iris
- ROI, DSP subregion (selectable ROI for auto features)
- Binning



- Auto gain (manual gain control: 0 to 48 dB)
- Auto exposure (manual exposure controls: 30 μ s to 60 s)
- Auto white balance
- StreamBytesPerSecond (easy bandwidth control)
- Stream hold
- Sync out modes: Trigger ready, input, exposing, readout, imaging, strobe, GPO
- Global shutter (digital shutter)
- Recorder and Multiframe acquisition modes
- Event channel
- Chunk data
- Storable user sets

Technical drawing

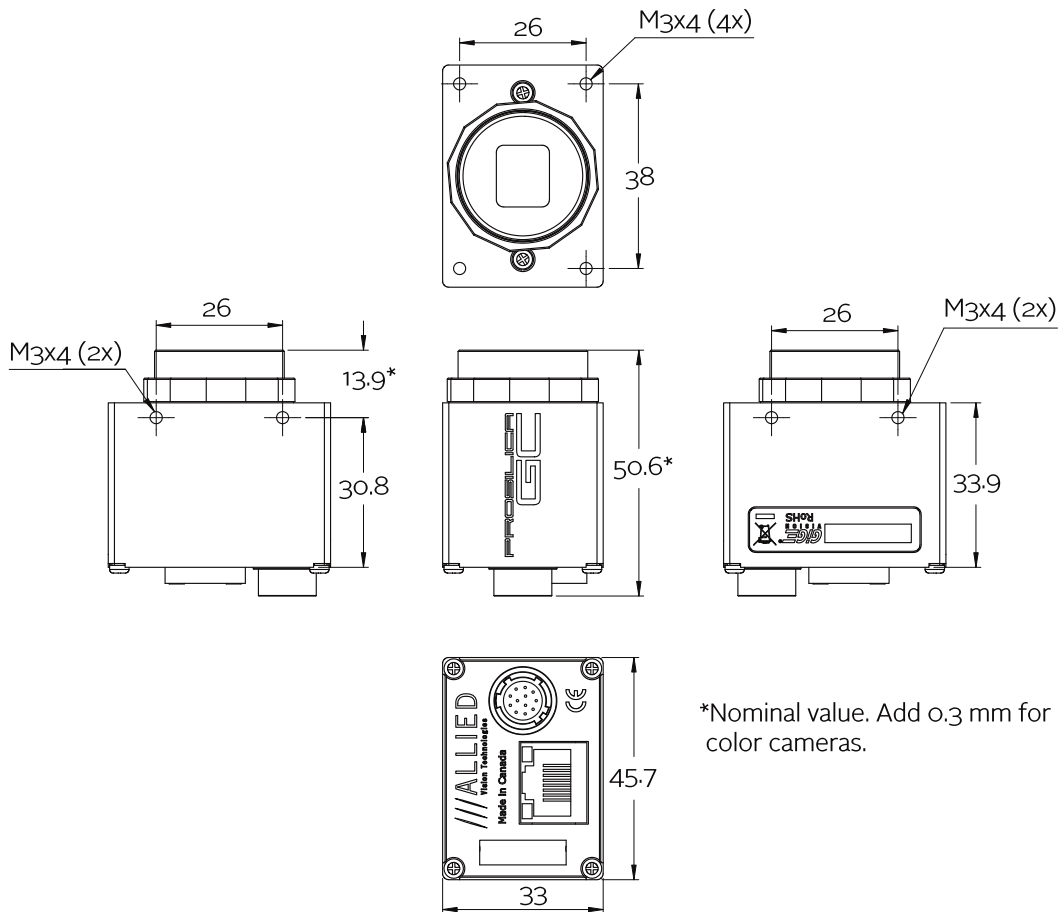



Applications

The CMOS sensor is suitable for applications where excellent near-IR sensitivity and resistance to blooming are required. These include:

- High-speed inspection
- Machine vision
- Optical character recognition
- Traffic imaging
- Robotics
- OEM applications