

Prosilica GC

1020



- Compact
- 33 fps @ 0.8 Megapixel
- Rugged housing
- Video-type auto iris

Description

XGA resolution ultra-compact CCD camera with GigE Vision

Prosilica GC1020 is a 1024 x 768 resolution CCD camera with Gigabit Ethernet interface (GigE Vision). GC1020 incorporates the Sony ICX204 CCD sensor providing excellent monochrome and color image quality. GC1020 runs over 30 frames per second at full resolution and even faster with region of interest readout.

Options

- IR cut filter, CS-Mount

Specifications

Prosilica GC	1020
Interface	IEEE 802.3 1000baseT
Resolution	1024 × 768
Sensor	Sony ICX204
Sensor type	CCD Progressive
Sensor size	Type 1/3
Cell size	4.65 μm
Lens mount	C (adjustable) / CS
Max frame rate at full resolution	33 fps
ADC	12 bit
On-board FIFO	16 Mbyte
Output	
Bit depth	8/12 bit
Mono modes	Mono8, Mono12, Mono12Packed

Prosilica GC	1020
Color modes RGB	RGB8Packed, BGR8Packed
Raw modes	BayerRG8, BayerRG12, BayerGR12Packed
General purpose inputs/outputs (GPIOs)	
TTL I/Os	1 input, 1 output
Opto-isolated I/Os	1 input, 1 output
RS-232	1
Operating conditions/dimensions	
Operating temperature	0°C ... +50°C
Power requirements (DC)	5-25 VDC*
Power consumption (@12 V)	2.9 W
Mass	99 g
Body dimensions (L × W × H in mm)	59 × 46 × 33 including connectors, w/o tripod and lens
Regulations	CE, FCC Class A, RoHS (2011/65/EU)

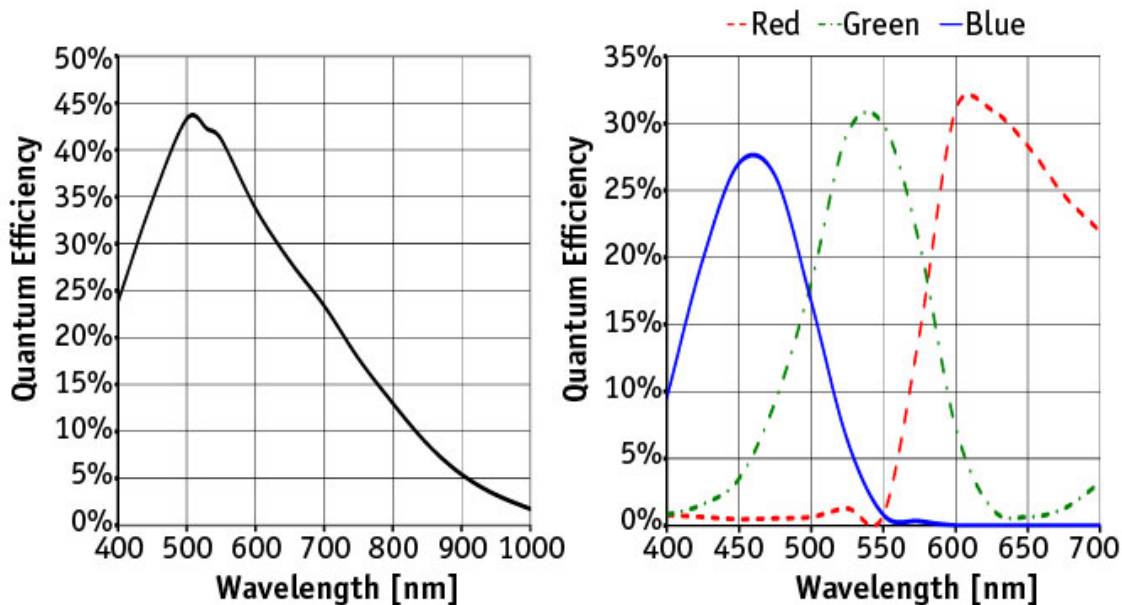

Features

Prosilica GC1020 features include:

- Video-type auto iris
- ROI, DSP subregion (selectable ROI for auto features)
- Binning
- Auto gain (manual gain control: 0 to 22 dB)



- Auto exposure (manual exposure controls: 10 μ s to 116.8 s)
- Auto white balance
- StreamBytesPerSecond (easy bandwidth control)
- Stream hold
- Sync out modes: Trigger ready, input, exposing, readout, imaging, strobe, GPO
- Global shutter (digital shutter)
- Recorder and Multiframe acquisition modes
- Event channel
- Chunk data
- Storable user sets

Technical drawing

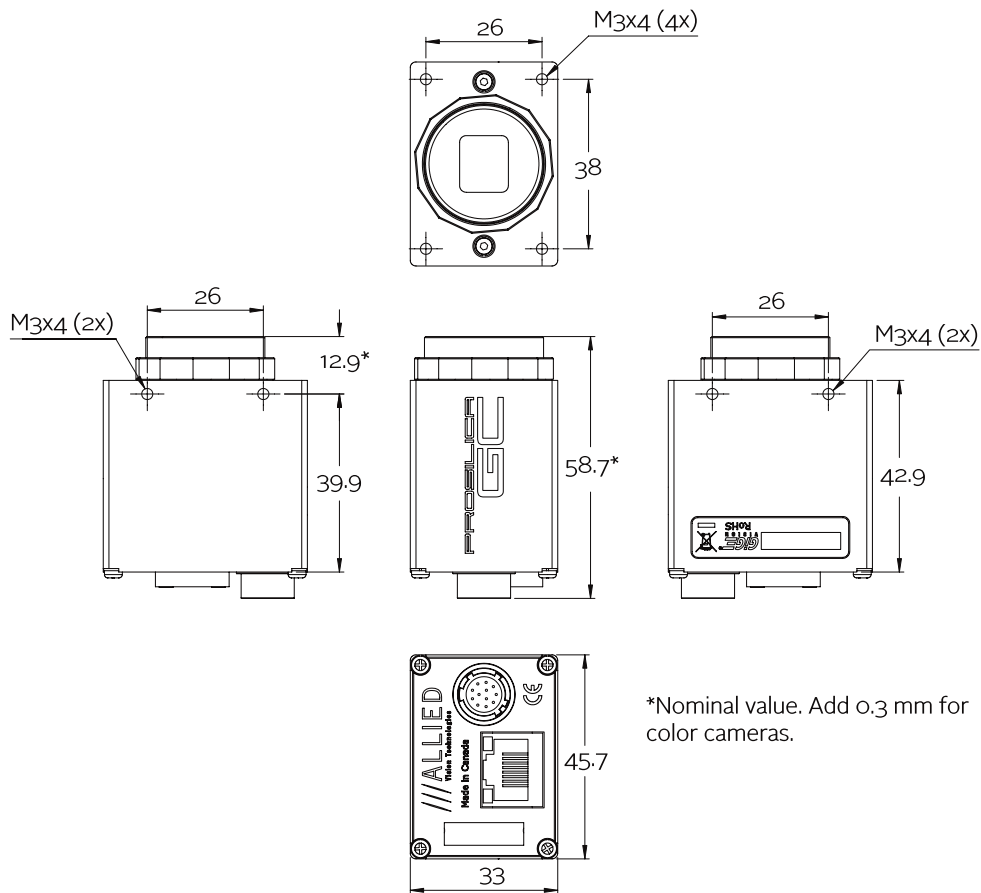



Applications

Prosilica GC1020 is ideal for a wide range of applications including:

- Industrial inspection
- Machine vision
- Ophthalmology
- Aeronautical and aerospace
- Public security
- Surveillance
- Traffic imaging
- OEM applications