



# Guppy PRO

## F-146



- Compact 1.4 MP camera
- Robust metal housing
- 17 fps
- Optocoupled I/Os

## Description

1394b camera with ICX267 - attractive price

The Guppy PRO F-146B/C is a 1394b camera with Sony's ICX267 CCD sensor. At full resolution, it runs 17 fps. Guppy PRO cameras have an ultra-compact, robust metal housing and a very attractive price.

Options

- Various IR cut/pass filters
- White medical housing

## Specifications

Guppy PRO	F-146
Interface	IEEE 1394b - 800 Mb/s, 1 port
Resolution	1388 × 1038
Sensor	Sony ICX267
Sensor type	CCD Progressive
Sensor size	Type 1/2
Cell size	4.65 μm
Lens mount	C-Mount
Max frame rate at full resolution	17 fps
ADC	12 bit
On-board FIFO	0 Mbyte
	<b>Output</b>
Bit depth	8-12 bit
Mono modes	8/12/16
Color modes RGB	RGB8

<b>Guppy PRO</b>	<b>F-146</b>
Raw modes	8/12/16
<b>General purpose inputs/outputs (GPIOs)</b>	
Opto-isolated I/Os	1/3
<b>Operating conditions/dimensions</b>	
Operating temperature	+5 °C ... +45 °C
Power requirements (DC)	8 V - 36 V
Power consumption (@12 V)	<3.5 W
Mass	80 g
Body dimensions (L × W × H in mm)	44.8 × 29 × 29 mm incl. connectors
Regulations	CE, FCC Class B, RoHS

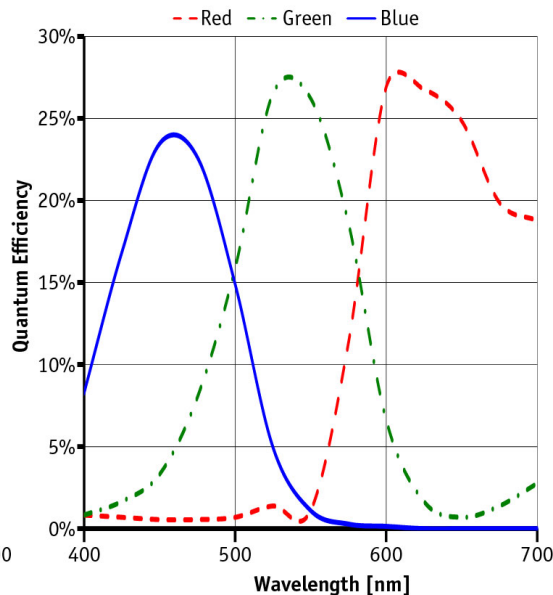
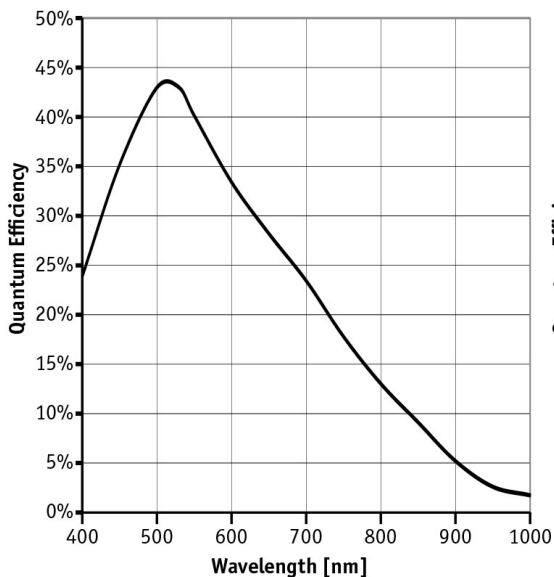

## Features

- LUT (look-up table)
- Gamma
- Color correction
- AOI, separate AOI for auto features
- Binning
- Sub-sampling
- Auto gain (manual gain control: 0 to 24.4 dB)
- Auto exposure (45  $\mu$ s to 67 s)
- Trigger programmable, level, single, bulk, programmable delay
- Storable user sets

## Technical drawing

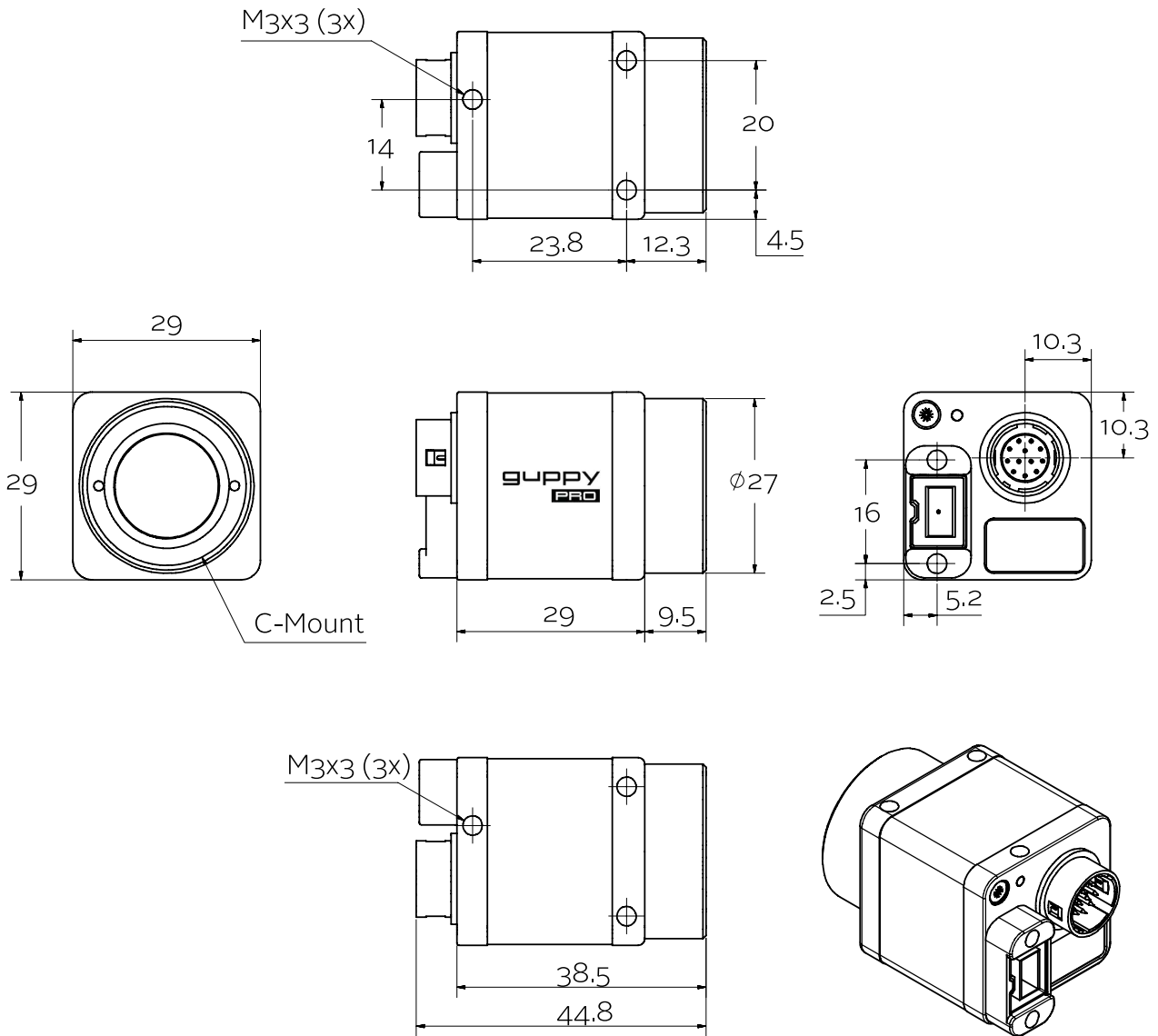

## Applications

The Guppy PRO F-146B/C is a very compact, robust 1394b camera. It suits for several applications:



- Machine vision
- Robotics
- Logistics
- Healthcare and medical imaging
- Pharmaceutical industry
- Multimedia
- Event documentation
- ITS/Traffic monitoring
- ... and more