



# Guppy PRO

## F-032



- Compact VGA camera
- Robust metal housing
- ICX424 CCD sensor
- Optocoupled I/Os

## Description

Industrial camera with ICX424 and 1394b interface

The Guppy PRO F-032B/C is an industrial camera with Sony's ICX424 CCD sensor and a fast 1394b interface. At full resolution, it runs 82 fps. Guppy PRO cameras have an excellent price/performance ratio. Options

- Various IR cut/pass filters
- White medical housing

## Specifications

<b>Guppy PRO</b>	<b>F-032</b>
Interface	IEEE 1394b - 800 Mb/s, 1 port
Resolution	656 × 492
Sensor	Sony ICX424
Sensor type	CCD Progressive
Sensor size	Type 1/3
Cell size	7.4 μm
Lens mount	C-Mount
Max frame rate at full resolution	82 fps
ADC	12 bit
On-board FIFO	0 Mbyte
	<b>Output</b>
Bit depth	8-12 bit
Mono modes	8/12/16
Color modes RGB	RGB8

<b>Guppy PRO</b>	<b>F-032</b>
Raw modes	8/12/16
<b>General purpose inputs/outputs (GPIOs)</b>	
Opto-isolated I/Os	1/3
<b>Operating conditions/dimensions</b>	
Operating temperature	+5 °C ... +45 °C
Power requirements (DC)	8 V - 36 V
Power consumption (@12 V)	<3.5 W
Mass	80 g
Body dimensions (L × W × H in mm)	44.8 × 29 × 29 mm incl. connectors
Regulations	CE, FCC Class B, RoHS

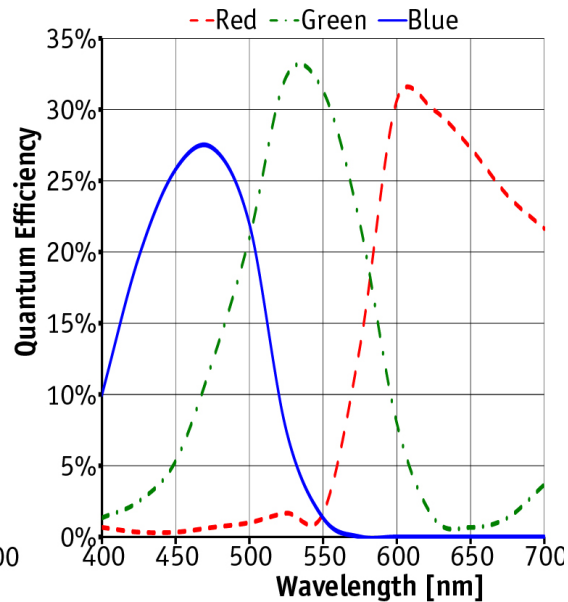
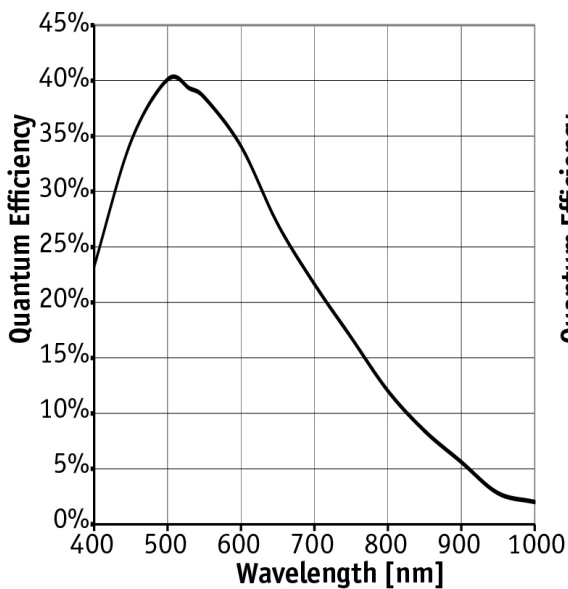

## Features

- LUT (look-up table)
- Gamma
- Color correction
- AOI, separate AOI for auto features
- Binning
- Sub-sampling
- Auto gain (manual gain control: 0 to 24.4 dB)
- Auto exposure (37  $\mu$ s to 67 s)
- Trigger programmable, level, single, bulk, programmable delay
- Storable user sets

## Technical drawing

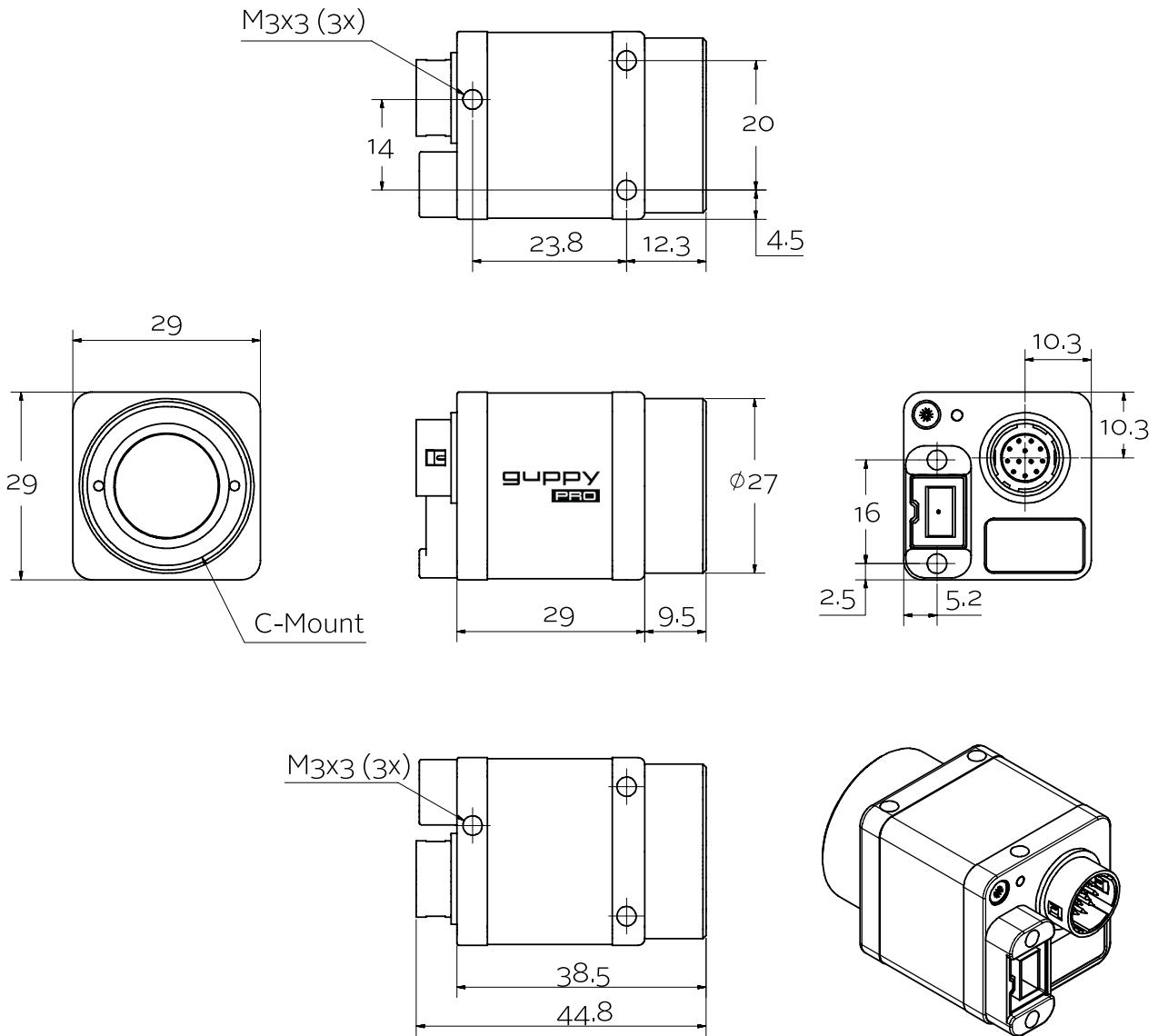

## Applications

The Guppy PRO F-032B/C is an ultra-compact 1394b camera for a large variety of industrial applications:



- Machine vision
- Robotics
- Logistics
- Security and Surveillance
- Healthcare
- Pharmaceutical industry
- Food inspection
- Motion analysis
- ITS/Traffic monitoring
- ... and more